

*Time Review*

# Continuation

TUCSON CORVAIR ASSOCIATION TUCSON, ARIZONA

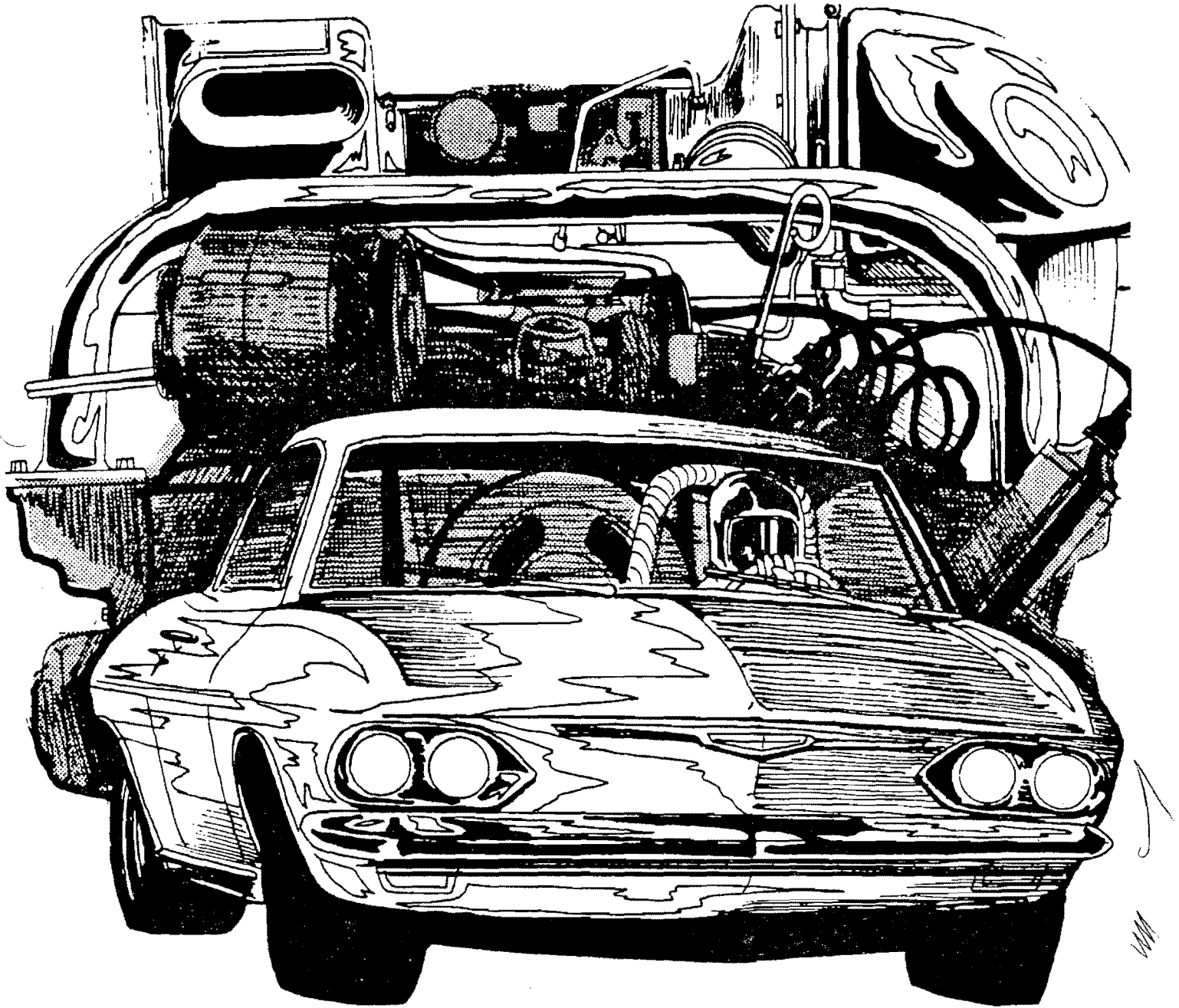

August, 1983

volume 9, Number 5

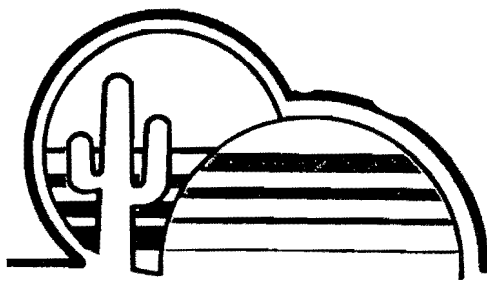

## TUCSON CORVAIR ASSOCIATION

---

CORVAIRSATION IS A MONTHLY NEWSLETTER FOR THE MEMBERS OF THE TUCSON CORVAIR ASSOCIATION AND OTHERS INTERESTED IN THE PRESERVATION AND RESTORATION OF THE CORVAIR AUTOMOBILE. THE TUCSON CORVAIR ASSOCIATION IS A CHARTERED CHAPTER OF CORSA (CORVAIR SOCIETY OF AMERICA)

MONTHLY MEETINGS ARE HELD ON THE 4th WEDNESDAY OF EACH MONTH. ONE ADDITIONAL SOCIAL AND/OR TECHNICAL EVENT IS PLANNED AND SCHEDULED EACH MONTH. DETAILS ARE PUBLISHED IN THE NEWSLETTER.

DUES FOR TUCSON CORVAIR ASSOCIATION MEMBERSHIP ARE \$10.00 PER YEAR, PAYABLE TO THE MEMBERSHIP CHAIRMAN. ANY TCA MEMBER WHO IS A MEMBER OF CORSA RECEIVES A \$1.00 DISCOUNT ON THEIR TCA DUES.

CORVAIR SOCIETY OF AMERICA (CORSA) MEMBERSHIP IS \$14.00 PER YEAR AND IS HANDLED DIRECTLY BETWEEN INDIVIDUALS AND CORSA AT, 2506 GROSS POINT ROAD, EVANSTON, IL. 60201.

DEADLINE FOR ALL MATERIAL FOR PUBLICATION IS THE 5th OF EACH MONTH. MATERIAL FOR PUBLICATION IS SOLICITED AND SHOULD BE TYPED IF AT ALL POSSIBLE. SEND ALL MATERIAL FOR PUBLICATION TO THE CORVAIRSATION EDITOR AT, 4471 E. 7th ST, TUCSON, AZ. 85711. PH. (602) 795-2639.

CLASSIFIED ADVERTISING IS FREE TO ALL TCA MEMBERS AND A \$ 2.00 PER/4-LINE AD TO NON-MEMBERS. COPY SHOULD BE MAILED TO THE CORVAIRSATION EDITOR AT THE ADDRESS LISTED ABOVE. COMMERCIAL ADVERTISING IS ARRANGED THROUGH, GORDON CAUBLE, 5950 N. CAMINO ARIZPE, TUCSON, AZ. 85718 PH: (602) 299-1122.

### PRESIDENT

VAN PERSHING  
4842 W. PASEO DE LAS COLINAS  
TUCSON, AZ. 85745  
PH: (602) 743-9185

### VICE PRESIDENT

BOB EGGERS  
9410 E. LURLENE DR.  
TUCSON, AZ. 85730  
PH: (602) 885-4779

### SECRETARY-TREASURER

ED CARY  
1501-A E. PRINCE ROAD  
TUCSON, AZ. 85719  
PH: (602) 327-4469

### RECORDING SECRETARY

LUCY POST  
114 N. AVENIDA CAROLINA  
TUCSON, AZ. 85711  
PH: (602) 326-3351

### EDITOR

DAVE THOMPSON  
4471 E. 7th ST.  
TUCSON, AZ. 85711  
PH: (602) 795-2639

### MEMBERSHIP CHAIRMAN

BOB THOMPSON  
619 S. MOUNTVALE DR.  
TUCSON, AZ. 85710  
PH: (602) 296-1991

### LIBRARIAN

DAVID MARTIN  
820 E. ADELAIDE DRIVE  
TUCSON, AZ.  
PH: (602) 884-7785

### DIRECTORS

DON BORTLE, ED SANFORD, BILL WILCOX, BOB THOMPSON, CORVAIRSATION EDITOR AND CURRENT OFFICERS.

## **PRESIDENT'S PAGE**

The National Convention is over for another year. Not many from Tucson got to go. I only know of a couple. Gordon Cauble flew up with Brian Lynch of Las Vegas and was good enough to attend the Chapter Officer's Meeting. We surely thank him for taking the time to do that. Next year the Convention will be in New Jersey, in 1985 it will go to Houston and in '86 it will be held in Salt Lake City. There was word that CORSA dues will be increasing by a whopping 57% and the insurance is changing again. There are presently 8,000 members of CORSA and enrollment is leveling off. Pete Kaylor is our new president. We'll go over more of the information in detail at the next meeting. All in all Gordon reported that the Convention was a good one and it had about the attendance as the Denver affair.

Please remember to show at 6:00pm for this month's meeting and we'll have a little swap meet/horse trading session as the first part of the meeting. Bring all of your good and not so good stuff and we'll all have a good time trying to figure out what it is that you have that we can't live without. If it proves to be a thing that will be successful, we'll try it on a regular basis of some sort.

In the meantime, I hope all of you are having an enjoyable summer and taking real good care of those Chevrolet Orphans.

A handwritten signature in cursive script that reads "Van". The signature is written in black ink and is positioned centrally below the text of the letter.

TCA REGULAR MEETING  
Wednesday, July 27, 1983

The meeting was called to order by the President, Van Pershing, at 7:37 p.m., at the Filling Station Restaurant, 6934 E. Tanque Verde Road.

PRESENT: 40      CORVAIRS: 22

The minutes of June 22, 1983 regular meeting as published in the Corvairsation were approved.

Visitors and new members were introduced.

There will be a car show called "Cars for Cure" at Hi-Corbett Field on August 13, 1983. The show is put on for the Multiple Scierosis Assn. Anyone interested in participating call Jim Tully for further information.

Ed Sanford asked for a show of hands for members interested in attending Tucson's dinner theatre, Le Theatre at 749 W. Miracle Mile, on Sunday, August 7th to see the comedy "How the Other Half Loves." Those interested make reservations with Ed at break along with monies to hold the reservation.

Frank McKenna thanked the members for the cards, calls and concerns while he was recuperating from his recent burns.

Word was received that Barney Goodwin, a member of TCA, had an accident while cutting limbs from a tree.

President, Van Pershing, stated at the board meeting it was agreed that family membership is now standard members of the immediate household. There will be one vote per family. The initiation fee was eliminated. Also discussed was a possibility of a hayride for January 1984.

Frank McKenna, Chairman of the Christmas Party, stated he had in mind the O.K. Corral or Panama Pete's for the Christmas Party. Any members desiring any other place to contact Frank.

Following break, grab bag and door prizes were won by Frank McKenna, Ed Sanford, Richard May, Alan Atwood, Robert Rentschler and Dave Thompson.

Sale items and technical tip sessions followed.

Prior to our August ~~21st~~<sup>24</sup> meeting, there will be a "Swap Meet" in the parking lot at the Filling Station Restaurant from 6:00 to 7:00 p.m. Members to bring items for sale, trade or whatever.

Meeting adjourned at 8:54 p.m.

Respectfully submitted,

*Lucy Post*

Lucy Post  
Recording Secretary

WELCOME NEW MEMBERS

The following new members joined TCA in July;

Joseph & Kurt Knittle  
840 E. Copper  
Tucson, Az. 85719  
692-2063

Richard & Joyce May  
373 N. Wilmot #321  
Tucson, Az. 85711

Robert Stout  
7621 E. La Cienega Dr.  
Tucson, Az. 85715  
298-2478

Victor Howard  
6270 N. Camino Arturo  
Tucson Az. 85718  
742-1823

CHANGE OF ADDRESS

UPDATE YOUR ROSTERS

Larry Dandridge  
1152 N. Alder Ave.  
Tucson, Az. 85705

Lee & Peggy Miller  
P.O. Box 126  
Cortaro, Az. 85230

Bill Wilcox  
951 S. Duke  
Tucson, Az. 85710

John North  
3113 Wiley Ave.  
Melbourne, Fl. 32910

WITH YOUR EYES CLOSED, IT WAS HARD TO TELL THE GREENBRIER  
AT 55 MPH FROM A B-29 AT 30,000 FEET!

Van Pershing

Whenever you say "rear wheel bearings" to a person who owns a Greenbrier, van or pick up, that person usually breaks into a cold sweat, gets a terrible head ache and begins shaking violently. About three years ago I did some major work on my Greenbrier and decided that as long as I had things apart I might as well replace the worn rear wheel bearings. "J.C." Clark had them advertised in his catalog so I thought I would give him a try. After about 8,000 miles the flanges with the bolt holes for mounting became so loose that I began to fear exceedingly. After another year of driving on them, one of them became very noisy so I began a search for some replacements. About that same time a place called Kingston Unlimited sent around a little flyer that had F.C. rear wheel bearings listed. I was really excited because the price of \$45 seemed fair enough and after talking with Wayne Kingston on the phone I was sure that they were not the same fine quality I had purchased from Clark. So I ordered a set.

The week end after they were installed my son, Adam, and I were on our way to a nice little place down by St. David, birthplace of my grandfather, for a little camping. I'll have to admit that after all that time with the noise, the new quiet bearings were really a treat and the speedometer was seen to touch the 75mph mark a time or two, and the dirt road we went on wasn't exactly the smoothest thing around but I really didn't think we did anything to the 'Brier that Chevrolet didn't design it to do. By the time we returned to Tucson, a whole 120 miles later, I began to hear some noise emanating from the rear of my vehicle. I knew what it was - the differential must be going to the dogs. No problem - I have a spare in the crawl space. A couple of hours and I'm back in the saddle again. But the noise is still there. Drat!!

Another call to Wayne Kingston. He thought he had sent me some "good" after-market replacements he had been getting (he didn't know the brand) when in fact he had sent a pair of Green Manufacturing units. I really didn't think anything of it when I installed them because they looked so much better than the Green bearings I had purchased from Clark - a completely different construction. He apologized but said there wasn't anything he could do since his bearing supplier couldn't get the other bearings he had been selling. The best he could do was return my money (which wouldn't make the 'Brier go down the road) or send me the best used ones he could find.

The day the "new" axles arrived happened to be the same day the July Corsa Communique arrived. By some strange coincidence there happened to be the best "how to" article I've ever seen in the Communique on cleaning and regreasing early model and F.C. rear wheel bearings. Two hours later I'm all ready to go. My wife happy with the prospect of not having to take all four kids to piano lessons in the 240Z and the Greenbrier not sounding like a B-29 cruising at 30,000 feet!!

P.S. I could have bought new original bearings from some of our less scrupulous Corvair "friends" for only \$150 each!!

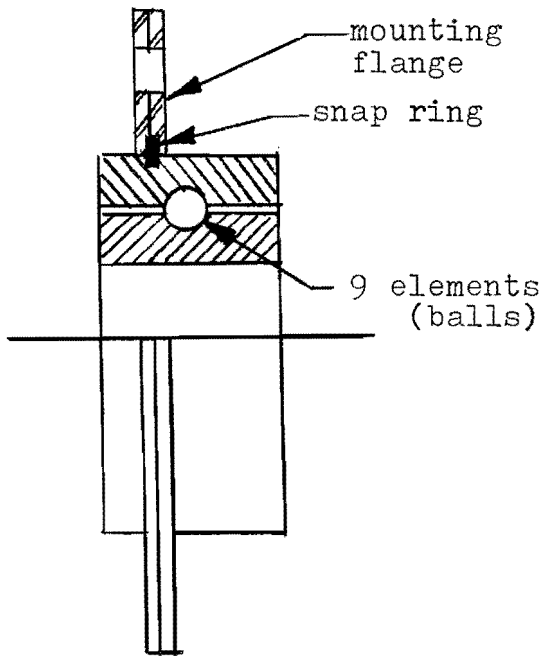

Figure 1: Green "first type"

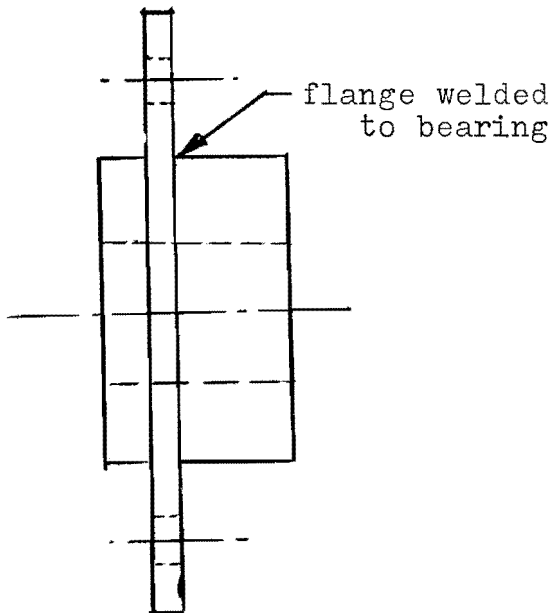

Figure 2: Green "second type"

The first bearing I replaced came from Clark's and were ball bearings manufactured by Green Bearing of Cleveland, Ohio. I will call them the "first Type". This bearing had 9 rolling elements (balls) and had a mounting flange that appeared to be pressed on, but in fact was held in place by a large snap ring. (figure 1). This really wasn't all that bad an idea. When bearing became used, the misalignment that the rear suspension needs, was taken up in the flange. It became loose. You can imagine what I must have thought when I first saw that! But the fault of the whole unit was with the bearing itself. Those 9 little balls just weren't up to the task.

The bearing I bought from Kingston were what I'll call "second type". These were also Green ball bearings but these were must different than the "first type" in that they were a nice sturdy solid welded construction. The flange wouldn't come loose on these babies! Really a nice looking unit. (Figure 2). Unfortunately looks were about all these bearings had going for them. With no misalignment capabilities at all, their life was very short - 300 miles max.

The original units were, of course New Departure/Hyatt double row spherical roller bearings. Being spherical means that all of the required misalignment was taken up right in the bearing itself causing no undue stress on the rolling elements. Double row means that there are basically two bearing in one. Each row contained 17 elements instead of the 9 in the Green bearings. The only basic fault with this bearing is that it does not last forever!

All of the above bearing are "sealed for life" type. Greased when they were made and sealed so the grease wouldn't escape.

# Classified Ads

---

WANTED: Rampside Door for '61 pickup. Call Lee Miller  
1-398-2050 Any day 6am til 10pm

FOR SALE: '66 Fitch Sprint Corsa coupe, 140hp, all original paperwork inc. Bill of Sale, Fitch conversion papers etc. Needs paint, Aztec Bronze, needs int. Runs good, has oil leaks. Needs total restoration, \$750 firm. Call Bob Gay at 298-1100.

FOR SALE: '66 Monza 2 door automatic \$750. Contact Don Bortle 298-4166

FOR SALE: Early and late Rear lenses - Tail & Back-up; Guide(GM) or Glo-Brite. Gordon Cauble 299-1122

FOR SALE: 1965 White Monza Coupe. Call Gordon Cauble for all the details at 299-1122.

FOR SALE: 1969 Convertible. Rebuilt '66 motor. Good paint, top, and original interior. \$4500 contact Neil Clements at 298-9633.

FOR SALE: '66 Monza 2 door automatic with 110 engine. 3 years ago rebuilt engine & transmission. Has new tires and battery. Body in good shape. Asking \$1,000 or best offer. Call Alfred Aguilar after 6 pm at 294-6590.

FOR SALE: Vinton "O" rings to seal the oil leaks in your engine, \$9.50/set. Air & oil filters. Weather strip for trunk & engine lid. Early & late shocks plus other hard to find parts for your Corvair. Gordon Cauble 299-1122

FOR SALE: '65 Corsa-140, recent valve job (May '83) total rebuild in May '81. Good radials, interior needs seats re-upholstered. I have new replacement carpet (A.C.P.) and misc. parts for restoration. 20 mpg in town. \$1400. Call Dave Tait after 4pm at 578-0089 or 746-7605 days.



*Jay's*



AUTO  
SUPPLY  
Inc.

**A Tucson Company...  
Serving Tucson!**

**We Love Corvairs —  
— We Have Many  
Corvair Parts . . .**

Knowledgeable, Courteous Counterme  
n on duty to help you!!

**WE CATER TO THE...  
"DO-IT-YOURSELF MECHANIC"**

4112 E. GRANT  
327-5991

5724 E. SPEEDWAY  
745-1414

1475 W. PRINCE  
887-8063

1618 S. CRAYCROFT  
790-2801

4227 S. 6TH  
889-5771



BOGARD & LARRIVA, P.C.

**STEVEN N. BOGARD**  
ATTORNEY AT LAW

15 W. WASHINGTON ST.  
TUCSON, ARIZONA 85701

(602) 624-4466

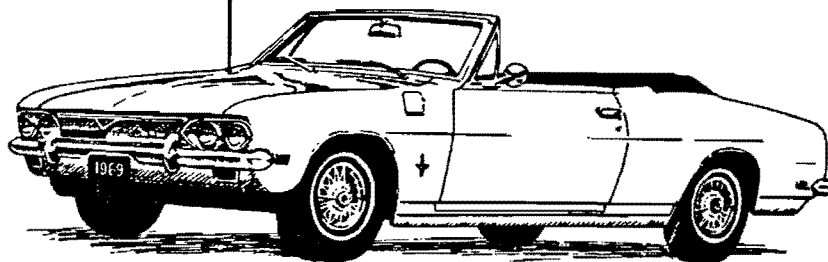

**TUNE-UPS**

**ENGINES REBUILT**

**ENGINE RESEALING**

**AIR CONDITIONING**

**15% OFF CORVAIR PARTS**

**BARNEY'S AUTO SERVICE**

**3029 NORTH ALVERNON WAY**

**881-1315**

**TCA MEMBERS KNOW**

**IT'S THE PLACE TO GO!!**



## Jerry Bishop

is wreckin' em out -  
100 plus Corvairs!!!

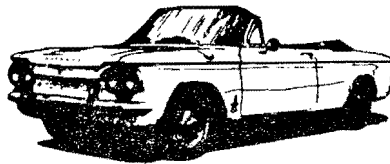

**JERRY BISHOP'S TOWING & SALVAGE 748-1444**  
**4260 E. ILLINOIS, TUCSON, ARIZONA 85714**



### JULY (PAST DUE)

Linda Coon  
Sam Angus  
Joseph De Wolf

### AUGUST

Ed Carey  
Louis Lage  
David Martin  
Milton Stanfill  
Larry Dandridge  
Don Hooks

### DUE IN SEPTEMBER

Don Robinson  
Will Ray  
David Albani

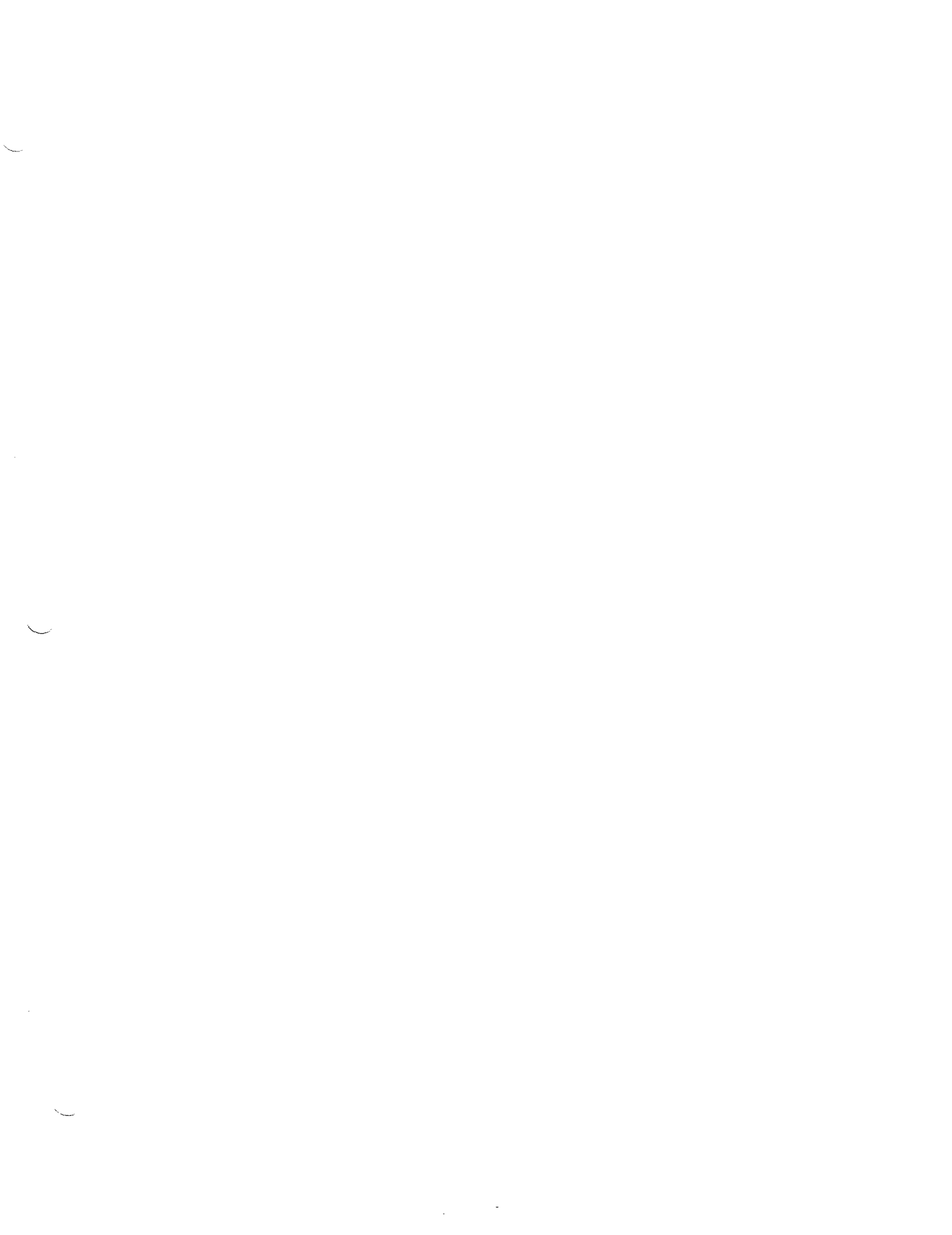

TUCSON CORVAIR ASSOCIATION REGULAR MONTHLY MEETING

- \* THE TIME: Fourth Wednesday of each month, 6:30 pm
- \* THE PLACE: The Filling Station, 6934 E. Tanque Verde Rd.
- \* THE MENU: An All-You-Can-Eat Buffet, Including Salad Bar
- \* THE COST (for the meal): \$3.99 plus drinks.

COMING  
EVENTS

SEPTEMBER 1983: Still up for grabs; What would you  
like to see the T.C.A. do this month?

The Tucson Corvaair Association is a chartered chapter of the Corvaair Society of America (CORSA). Monthly meetings are held on the 4th Wednesday of each month.

CORVAIRSAATION EDITOR  
4471 E. 7th ST.  
TUCSON ARIZONA 85711

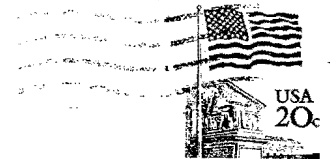

FIRST CLASS MAIL



Dave Baker  
7041 Arrowhead Dr.  
Tucson, AZ 85715  
296-1392 Dec.