

Conversation

IN THIS ISSUE:

Park Mall Show Coming
Christmas Party Report
New Editor's Comments

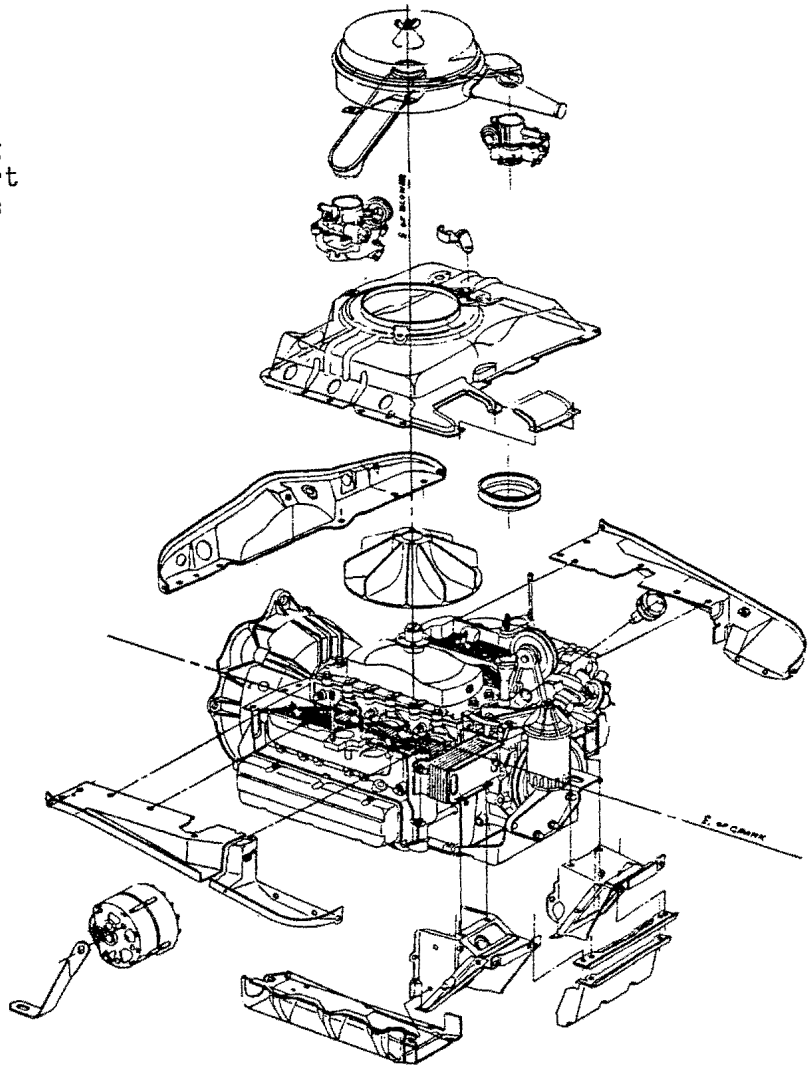

JANUARY 1983

VOLUME 7 NUMBER 10

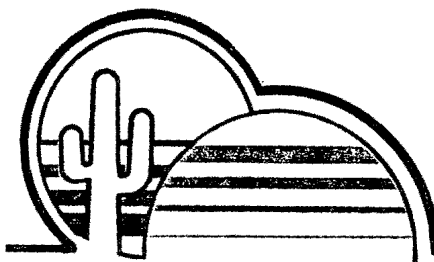

TUCSON CORVAIR ASSOCIATION

CORVAIRSATION IS A MONTHLY NEWSLETTER PRINTED FOR THE MEMBERS OF THE TUCSON CORVAIR ASSOCIATION AND OTHERS INTERESTED IN THE PRESERVATION AND RESTORATION OF THE CORVAIR AUTOMOBILE. THE TUCSON CORVAIR ASSOCIATION IS A CHARTERED CHAPTER OF CORSA (CORVAIR SOCIETY OF AMERICA) AND MEMBERS OF THE TUCSON CORVAIR ASSOCIATION ARE REQUIRED TO JOIN AND MAINTAIN MEMBERSHIP IN CORSA.

MONTHLY MEETINGS ARE HELD ON THE 4TH WEDNESDAY OF EACH MONTH. ONE ADDITIONAL SOCIAL AND/OR TECHNICAL EVENT IS HELD EACH MONTH. DETAILS ARE PUBLISHED IN THE NEWSLETTER.

DUES FOR TUCSON CORVAIR ASSOCIATION MEMBERSHIP ARE \$9.00 PER YEAR, PLUS AN ADDITIONAL \$2.50 UPON INITIAL JOINING. FOR FAMILY MEMBERSHIP, ADD \$1.00 PER YEAR. CORVAIR SOCIETY OF AMERICA MEMBERSHIP IS \$14.00 PER YEAR AND IS ACCOMPLISHED DIRECTLY BETWEEN INDIVIDUALS AND CORSA AT 2506 GROSS POINT ROAD, EVANSTON, IL 60201.

DEADLINE FOR ALL MATERIAL FOR PUBLICATION IS THE 2ND TUESDAY OF THE MONTH. CONTRIBUTIONS ARE SOLICITED AND SHOULD BE TYPED IF AT ALL POSSIBLE. SEND TO CORVAIRSATION EDITOR AT 4842 W. PASEO DE LAS COLINAS, TUCSON, ARIZONA 85745. PH: (602) 743-9185

CLASSIFIED ADVERTISING IS FREE TO MEMBERS AND \$2.00 PER 4-LINE AD TO NON-MEMBERS. COPY SHOULD BE MAILED TO THE EDITOR AT THE ADDRESS LISTED ABOVE. COMMERCIAL ADVERTISING IS ARRANGED THROUGH GORDON CAUBLE, 5950 N. CAMINO ARIZPE, TUCSON, ARIZONA 85718 PH: (602)299-1122.

PRESIDENT

ED SANFORD
1710 S. CEYLON PL.
TUCSON, ARIZONA 85710
(602)855-9214

EDITOR

VAN PERSHING
4842 W. PASEO DE LAS COLINAS
TUCSON, ARIZONA 85745
(602) 743-9185

VICE PRESIDENT

VAN PERSHING
4842 W. PASEO DE LAS COLINAS
TUCSON, ARIZONA 85745
(602) 743-9185

MEMBERSHIP

GEORGIA LEWIS
6657 E. 17th STREET
TUCSON, ARIZONA 85710
(602) 747-1692

SECRETARY-TREASURER

ED CAREY
1501-A E. PRINCE ROAD
TUCSON, ARIZONA 85719
(602) 327-4469

LIBRARIAN

DAVID MARTIN
820 E. ADELAIDE DRIVE
TUCSON, ARIZONA 85719
(602) 884-7785

RECORDING SECRETARY

LUCY POST
114 N. AVENIDA CAROLINA
TUCSON, ARIZONA 85711
(602) 326-3351

DIRECTORS

PAT HAYHURST, DON BORTLE,
DON CHASTAIN, GEORGIA LEWIS,
CORVAIRSATION EDITOR AND
CURRENT OFFICERS

The Prez Sez---

Happy New Year!! Here's hoping 1983 will bring fewer thrown fan belts, fewer oil leaks, fewer strange and awesome noises from the engine compartment, more gas mileage, more envious looks as you drive your 'Vair down Speedway, and more fun that comes from driving a neat car!

How about that Christmas party! Good food, good company, and door prizes for everyone. Afterwards, I went looking for the waitress who absconded with ticket #522. I wanted her to go to Frank McKenna & demand her door prize. I didn't find her, and it's probably a good thing--- I can just see Frank trying to explain it to his wife when a strange girl comes up to him and says "I understand you have something for me"--- Mayhem at the O.K. Corral, second verse!

Elections are coming up real soon--- I have my hit men out scouring up nominees. Do your duty!

Economy run to the Boyce Thompson Arboretum on Jan 16--- picnic too. If you get this prior, join the fun. If not, hope we saw you there.

Now, I've got to see about a sticking valve on #5--- I didn't think valves ever went bad on 'Vairs, did you? See you next time-----

Big Ed

PARK MALL '83

OK T.C.A. It's time to show the public that CORVAIRS are still alive and running. You guessed it, it's PARK MALL SHOW TIME FOR '83. February 12th and 13th. Let's show Tucson that we have a large enthusiastic CORVAIR CLUB.

The requirements for the park mall show are minimal. You do not have to have a car in concours show condition. Just CLEAN AND WELL CARED FOR, a few parking lot paint chips won't hurt. Mine has a few paint chips, a couple of areas of cracked paint, and some oxidation that I can't rub out, but it's going in anyway. Things like that can't be helped when you like to drive your car every day like I do. Other requirements include: 1. You must only have a minimum supply of fuel in the gas tank, all other safety requirements will be taken care of after the cars are positioned in the mall. Such as, disconnect and tape battery terminals, and tape gas caps. This is a must, anyone showing a car MUST BE A MEMBER OF T.C.A. AND CORSA. This is an insurance company requirement and there is no way around it.

There is one more necessity for a successful show, and that is VOLUNTEERS to answer questions about our club such as, where we meet, how do I join? etc, help keep little sticky fingers off the paint. Volunteers need only spend a couple of hours one of the two days, on the other hand we won't make you leave if you want to stay longer. I will have a sign up sheet at the January meeting.

I must notify Park Mall by Feb. 1st, how many cars we are going to display. I also need a volunteer with a good camera to take pictures for publication.

Last year I was able to obtain some T.V. news coverage. It was minimal and at the last minute, but we were competing with a much larger car show at the community center called The World of Wheels, and the fact we only had 13 corvairs on display didn't help much.

I believe if we had 30 or 40 Corvairs on display and no other car shows that weekend, we could do much better on the publicity end. The World of Wheels show this year is Feb. 4th, 5th, and 6th.

I have the entire aisle from Sears Roebuck to The Broadway reserved for our show this year, so lets fill it up with CORVAIRS. With 80 plus members and at least that many good looking corvairs, I see no reason why we can't.

All car owners showing cars will meet at the main entrance to the mall (The east broadway entrance) no later than 7:00 A.M. so we can get them lined up ready to enter the mall by 7:30 A.M. we have a lot to do after the cars are positioned in the mall and I for one, would like to go buy some breakfast at least by 9:00 A.M. I also PROMISE to be there on time this year, as we all know, I over slept last year.

Jan or I can be reached at 296- 1991, for anyone wanting to show their car or otherwise volunteer and won't be at the Jan. meeting.

Bob Thompson

CARBURETOR JETTING

Here's a tip that just might be worth a try. Greater economy can be achieved by jetting your carburetors richer! Corvairs normally have #50 or #51 main jets. By going from #51 jets in all carburetors (140 HP in this example) to #54 jets, the results should be a cooler running engine, approximately 5 degrees additional spark advance and 1 to 2 miles more per gallon. Be sure to use the Rochester jets that have to 60 degree chamfer.

North Central Corvair Ass'n of Minnesota

TUCSON CORVAIR ASSOCIATION ANNUAL CHRISTMAS PARTY
RATED "GREAT" BY ALL

On Wednesday evening, December 15, 1982, the annual TCA Christmas Party was held at the OK Corral here in Tucson. There were 57 people in attendance and a great time was had by all. The food was good and there were plenty of door prizes for all as well as a few left over that will be used as grab bags and/or will be sold by the merchandise chairman. Things got rolling about 6:30pm and finished up around 10:30. Special guests in attendance were our advertisers which included Phil Harris from the Parts Department at Matthews Chevrolet; Barney Goodwin of Barney's Auto Service, Jerry Bishop of Jerry Bishop's Towing and Salvage; and Bill Wilcox of Amphi Body Shop. A very special thanks goes out to Bob and Jan Thompson and Betty Chastain for getting all the door prizes together. There are some rumors going around concerning the degree of enjoyment had by one Frank McKenna due to the quantities of liquid refreshment which he allegedly consumed but nothing more will be said about the number 522 or the waitress involved!

NON-INTERCHANGABLE STEERING

If there's one thing that has changed on the Corvaire with each production year, it could be the steering. Most people, when they replace the steering gear box, change the box and shaft(s) from a junker as a complete assembly, especially if it's not from your model year. While this usually works well, don't try to install '67 - '69 steering in a '65 or a '66 or visa versa unless you're prepared for major rework. The '67-'69 assembly is of the collapsed-column design, and it incorporates a steering wheel that is less dished than previous years, hence the shaft is longer to place the wheel in a comfortable driving position. The mast jacket is also thicker - and longer. The omega-shaped under dash bracket that supports the jacket has its two mounting holes spaced about $\frac{1}{2}$ " further apart to accommodate the larger jacket, so the bracket won't bolt up. The hole in the bulkhead (firewall) is also 1" larger. This, of course, means that the three flange bolt holes are relocated and, to add insult to injury, the coupling located at the gearbox interferes with the frame. Now here's the good news! The standard '67-'69 boxes have a faster ratio - about 4 turns vs. 5 turns lock to lock.

CORVAIRSATION FINDS NEW EDITOR

or

There's one born every minute!

It's probably not going to be as bad as one might imagine; in fact, it looks like it's going to be a lot of fun! At any rate, I'm all you got so let's make the best of it.

First, we would like to thank Lou and Lera Lage for the fine job they have done as editors. It is my hope that we can continue to uphold the same standards that the Lage's have set and make improvements where possible.

When you stop to think about it, the Corvairsation really offers us some terrific services - and when we say that we are really saying that we, the club members are offering each other these services. The Corvairsation is nothing more than an extension of the Tucson Corvair Association. Here's what I mean:

Want Ads are available at no charge to members. Here we can advertise any item we wish to a group of potential customers that is taylored for your Corvair item. You can buy, sell or trade. I'd like to see a complete page of nothing but want ads in every issue. And they are easy to place - just call the editor and tell him exactly what you want.

Tech Tips and General Interest Articles are found in every issue of the Corvairsation, but they don't get there by themselves. They come from the general membership of the club. They don't have to orginal expertly done literary works - they just have to be something you would like to see in the Corvairsation. So just call the editor with an idea or mail him an article. Easy, isn't it?

Artwork is another item that is always nice to see in the Corvairsation. We are always robbing from here and there to find things that dress up the newsletter - it sure would be good to see the work of some of you more talented folks adorning the pages of the Corvairsation!!

Monthly Events and Activities will be covered in detail by the Corvairsation. We'd like to see a general policy established that would allow the chairman of an event or activity to be responsible for the pre-event publicity as well as they post-event report. This would give us complete first-hand coverage.

Advertisers place their ads in the Corvairsation so we can keep abreast of what is available to us from local people. It's good to know where we can go to get certain services and goods. Let's be sure we support them whenever we can.

The bottom line to all this is that we should use the Corvairsation as much as we can. We should likewise give the Corvairsation as much as we can. I really feel that whatever we give will be returned to us many fold.

Van Pershing, Editor

CORVAIRSATION SUBSCRIBERS WE WISH WERE TCA MEMBERS

If you have been misclassified please call the Membership Chairman (Georgia Lewis, 790-1692) and advise her of your CORSA membership number. Unfortunately our CORSA Membership List is currently outdated.

Alfred P. Aguilar
Dave Baker
W. D. & Frances Berkey
Edward L. & Jane Cook
Lawrence D. Dandridge
Joseph M. DeWolf
Len Droz
Clarence L. Elkins
Ken Fadal
Emit Thomas Lamanda
Henry J. Lannoo
Edward Madden
Tellis & Susan Martell

Floyd R. McKiernan
Dave & Darby Michaels
Daniel F. Miles
Don & Joan Notter
Arnold & Ruth Oggier
David & Harriet Pakula

Craig W. Pottinger
John & Phyllis Roach
Richard E. Schreiner
Bill Sears
Dave Stafford
Fred & Linda Sullivan

Should you wish to join the Tucson Corvair Association you may contact the Membership Chairman and she will furnish you with a CORSA (Corvair Association of America) application. CORSA membership fee is \$14 per year which includes a subscription to their monthly magazine, Communique.

D * A * S * H

EXPIRATIONS - JANUARY

Don & Marty Bortle, Members
W. D. & Frances Berkey, Subscribers
Floyd McKiernan, Subscriber
George & Helen Ford, Members
Neil C. Clements, Member
Dave Tait, Member
James Wright, Member
Richard & Jeanne Lucht, Members

EXPIRATIONS - FEBRUARY

Gordon Cauble, Member
Darrell E. Hayhurst, Member
Don & Betty Chastain, Members
Alan Atwood, Member
Al Aguilar, Subscriber
Steven R. Estabrook, Member
Edward & June Cook, Subscribers
Thomas Locasio, Member
Bill Wilcox, Member
William R. Sears, Subscriber
Don & Joan Notter, Subscribers

NEW MEMBERS- DECEMBER

Cecil & Rosalle Allain
Lee Spitzer
Woodroe L. Wilkins

CLASSIFIED ADS

FOR SALE: 1964 Corvair Convertible, needs restoration - engine okay, needs upholstery and top. New tires. Offers around \$750.
Bill Wilcox (602) 623-9654

FOR SALE: TELESCOPIC STEERING Wheel.
Frank McKenna (602)885-8571

FOR SALE: '63 4dr, body good, glass good, bad interior, 2 engines, may run.
Ask for Robert Sharp. 623-6324

FOR SALE: CORSA Dash and glove box, \$75. 140 HP air cleaner assembly, \$75.
Gordon Cauble (602) 299-1122

FOR SALE: '66 4dr with factory 140 HP, 4spd. Asking \$500 OBO
Call Gordon Cauble (602)299-1122

FOR SALE: '65 CORSA TURBO, 4spd, fully restored, very clean, metallic gray w/ gray and black striped interior.
Marilynn McManus (602)293-4149

FOR SALE: VITON "O" Rings to seal the oil leaks in your engine, \$9.50 set. Air and oil filters. Weather-strip for trunk and engine lid. Early and Late shock absorbers plus other hard to find parts for your Corvair.
Gordon Cauble (602) 299-1122

FOR SALE: Ignition wire sets for your Corvair with original-style boots. Fuel pump repair kits, \$8.50. Wrapped fan belts and many other parts and accessories.
Gordon Cauble (602) 299-1122

TREASURERS REPORT

Ed Carey

| | |
|----------------------|------------|
| Balance 12/1/82..... | \$1,883.29 |
| Income..... | \$191.36 |
| Expenses..... | \$327.36 |
| Balance 1/1/83..... | \$1,727.29 |



Jerry Bishop
 is wreckin' 'em out --
 100 plus Corvairs!!!!!!

JERRY BISHOP'S TOWING AND SALVAGE, 4260 E. Illinois,
 Tucson, AZ 85714 602-748-1444

Paint & Body restorations
 by professional craftsmen.
 Since 1960

AMPHI BODY SHOP
 3220 N. STONE AVENUE
 TUCSON, AZ 85705

Completes - spot repairs - color
 matching a specialty

888-1440 BILL WILCOX

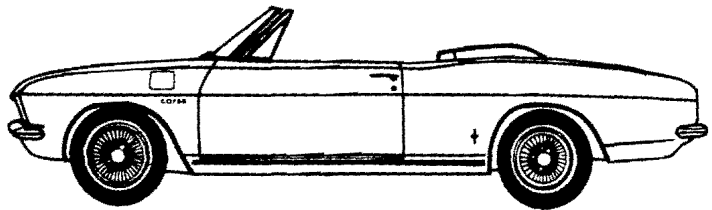
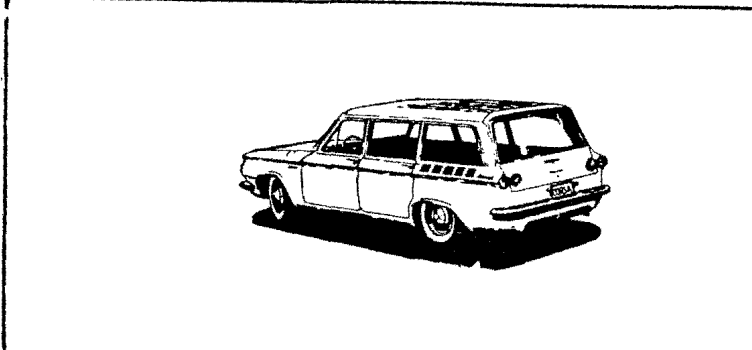

TUNE-UPS ENGINE RESEALING
 ENGINES REBUILT AIR CONDITIONING
 15% OFF CORVAIR PARTS

BARNEY'S AUTO SERVICE
 3029 North Alvernon Way
 881-1315

TCA MEMBERS KNOW IT'S THE PLACE TO GO !!

Jay's



**AUTO
SUPPLY
Inc.**

**A Tucson Company...
Serving Tucson!**

**We Love Corvairs —
— We Have Many
Corvair Parts . . .**

**Knowledgeable, Courteous Counterme-
n on duty to help you!!**

**WE CATER TO THE...
"DO-IT-YOURSELF MECHANIC"**

4112 E. GRANT
327-5991

5724 E. SPEEDWAY
745-1414

1475 W. PRINCE
887-8063

1618 S. CRAYCROFT
790-2801

4227 S. 6TH
889-5771



BOGARD & LARRIVA, P.C.

**STEVEN N. BOGARD
ATTORNEY AT LAW**

15 W. WASHINGTON ST.
TUCSON, ARIZONA 85701

(602) 624-4466



CORVAIR PARTS:

When you own a distinctive automobile like the Corvair, parts and accessories are important. You can't keep your car running without them. And because they're important to you, they're important to us. Matthews Chevrolet still maintains an extensive inventory of Corvair Parts and accessories, and our service department continues to service all models of Corvairs with tender loving care. Honestly!

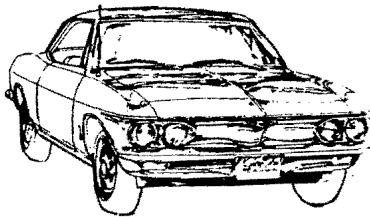

MATTHEWS CHEVROLET

22nd & Park

792-3950

PARTS DEPT. OPEN

7:00 6:00

MON - FRI

TUCSON CORVAIR ASSOCIATION REGULAR MONTHLY MEETING

- * THE TIME: JANUARY 26, 1983, 6:30pm
- * THE PLACE: The Filling Station, 6934 E. Tanque Verde Rd.
- * THE MENU: An All-You-Can-Eat Buffet, Including Salad Bar
- * THE COST (for the meal): \$3.99 plus drinks.

COMING
EVENTS

FEBRUARY 12 & 13: Park Mall Corvair Show.
Call Bob Thompson for details
at 296-1991. Get your car
cleaned up and come on down
and let's show the world that
Nader really was wrong!!

The Tucson Corvair Association is a chart-
ered chapter of the Corvair Society of
America (CORSA) and its members are required
to join and maintain membership in CORSA.
Monthly meetings are held on the 4th Wednes-
day of each month.

CORVAIR SATION EDITOR
4842 W. PASEO DE LAS COLINAS
TUCSON, ARIZONA 85745



FIRST CLASS MAIL



Bryan & Marilyn Lynch
7405 Blizzard Court
Las Vegas NV 89128

Life