

## Designing the Corvair announcement ads

By Harry Borgman

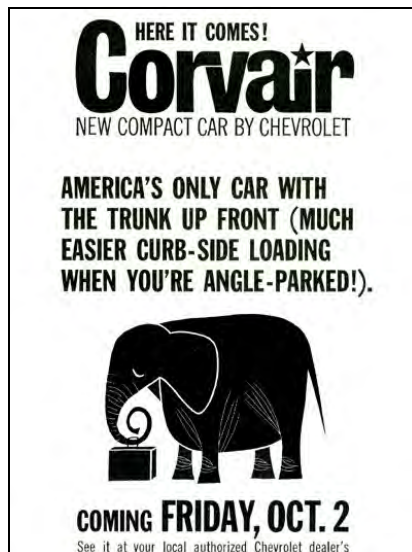

When I decided to leave Campbell Ewald I was immediately rehired as a freelancer to work on a top secret project, the announcement ads for the Corvair. CECO even set me up in a special office in the GM building. I couldn't let anyone in my office or tell anyone just what I was doing. The CECO employees frequently ran into me and were very curious as to what I was up to. What was I doing in the GM building every day after I had just quit CECO? This project was so secretive that when I had to have type set I used two or three different typesetters, breaking up the headlines so that they made no sense, then reassembling the words later. I was also frequently in the CECO offices which made the whole thing more mystifying to the art directors and others. I can't remember the time frame but it went on for two or three months I believe. I have always been heavily involved with drawing cartoons and that was the direction I took in designing these ads. It was a fun project and a great way for me to launch my freelance career.

Using solid black drawings with bold type created very strong images that stood out well in the newspapers, the readers couldn't miss these ads! Thanks to Dave Newell, Chevrolet historian, for sending me all of these images. I, like most artists, have kept only a small portion of all of the work done over the years. It's great when someone like Dave can supply some of these long forgotten items.

To see more go to:

[harryborgmanart.blogspot.com/2009/01/corvair-announcement-ads.html](http://harryborgmanart.blogspot.com/2009/01/corvair-announcement-ads.html)

## Sebring convertible seats for your Corvair



One way to install three-point seat belt in your Corvair is to replace your stock bucket seats with Chrysler Sebring convertible units. Since these seats have the shoulder belts integrated into the seat back, they can be used in Corvair convertibles as well as coupes and sedans. The seats from the 1996 to 1998 model Sebrings are preferred.

Stock Sebring seats are often seen in Corvairs, but they can be modified to change the look if you prefer. To take advantage of all the features these seats offer is quite a complicated process but details can be found at [www.corvairkid.com/sebring.htm](http://www.corvairkid.com/sebring.htm).



*A set of stock Sebring seats (above left). A set of Sebring seats that have been modified for a more conventional look (above). A nicely reupholstered stock set installed in a late model coupe (left).*



**TUCSON CORVAIR ASSOCIATION**  
Established 1975

**TCA 2016 Events at a Glance**

The **Corvairsation** is a monthly publication of the Tucson Corvair Association, which is dedicated to the preservation of the Corvair model of the Chevrolet Motor Division of General Motors. The Tucson Corvair Association is a chartered member of the Corvair Society of America (CORSA) as Chapter 357.

**Membership dues** are \$15 per year for individuals and \$18 for families. Initial dues are \$19 for individuals and \$22 for families (includes one name tag). Make checks payable to the Tucson Corvair Association and mail to the TCA Treasurer.

**Change of Address:** Report any change of address or phone number to the Membership Chairperson.

**CORSA membership** dues are \$45 per year (\$90 for 26 months) and include a subscription to the CORSA Communiqué, a bi-monthly publication. CORSA memberships is not required for membership in the Tucson Corvair Association, but is highly recommended. See any TCA officer for more information.

**Business Mailing Address:** 4842 W Paseo de las Colinas, Tucson, Arizona 85745  
**Website address:** [www.corvairs.org](http://www.corvairs.org). Email address: [tucsoncorvairs@yahoo.com](mailto:tucsoncorvairs@yahoo.com)

**Feb 24, Wed**

**Regular Monthly Meeting.** Parking Lot Bull Session at 6:30pm. Meeting starts at 7:00pm. Pizza Hut, 2942 N Campbell (2 blocks south of Ft Lowell).

**Feb 20, Sat**

**3rd Annual Caliente Clowns Car Show.** 8am to 1pm. Caliente del Sol, 3502 N Pinal Parkway, Florence, Arizona. See TCA website for registration form and details. [www.corvairs.org](http://www.corvairs.org)

**Apr 30, Sat**

**31st Annual Chevy Showdown,** Casino del Sol Resort, 5653 W Valencencia Rd, Tucson, Arizona. 9am to 3pm. Go to [www.corvairs.org](http://www.corvairs.org) for details and registration form.

**WHEELS AND SPOKES**

**PRESIDENT**

**Mike Lake**  
520-979-0310  
[mils56@g.com](mailto:mils56@g.com)

**VICE PRESIDENT**

**Sam Pernu**  
520-749-3229  
[spernu3@gmail.com](mailto:spernu3@gmail.com)

**RECORDING SECRETARY/  
CORVAIRSATION EDITORS**

**Frank & FJ Trejo**  
480-459-6308  
[essedave@gmail.com](mailto:essedave@gmail.com)

**TREASURER**

**Allen Elvick**  
4210 S Preston  
Tucson, AZ 85735  
520-883-4437  
[amelvick@pcpeople.com](mailto:amelvick@pcpeople.com)

**MEMBER AT LARGE**

**Gloria Trejo**  
480-459-6309  
[tucsonglo@gmail.com](mailto:tucsonglo@gmail.com)

**MEMBERSHIP CHAIRMAN**

**Ron Bloom**  
Tucson, AZ 857  
520-891-7542  
[bloomaz@msn.com](mailto:bloomaz@msn.com)

**WEBMASTER**

**Van Pershing**  
520-743-9185

**ASSISTANT EDITOR**

**Chris Cunningham**  
520-240-9035  
[arizaim@hotmail.com](mailto:arizaim@hotmail.com)

**IMMEDIATE PAST PRESIDENTS**

**Lynn Marrs**  
520-297-8969  
[lareservemanager@yahoo.com](mailto:lareservemanager@yahoo.com)

**Ron Bloom**

**LIBBRARIAN**  
**Bill Maynard**  
3605 N Vine  
Tucson, AZ 85719  
520-325-8497  
[billmaynard@webtv.com](mailto:billmaynard@webtv.com)

**MECHANDISE CHAIRMAN**

**Don Robinson**  
520-297-1356  
[fourcorvairs@hotmail.com](mailto:fourcorvairs@hotmail.com)



*A new roof for FJ's car*

**2016 TCA Officers**

The slate of officers has been decided for the 2016 Tucson Corvair Association.

- President: Bill Maynard**
- Vice President: Sam Pernu**
- Recording Secretary: Frank Trejo**
- Treasurer: Allen Elvick**
- Board Member-at-large: Mike Lake**
- Membership Chairman: Ron Bloom**

These officers will be ratified by the general membership at the regular Club meeting on Wednesday, February 24. Come support our new officers.

MADE IN



U. S. A.

MADE IN



U. S. A.

MADE IN



U. S. A.

MADE IN



U. S. A.



## January Meeting Minutes

Minutes from the monthly meeting held January 27, 2016 at Golden Corral, 4380 E 22nd Street, Tucson, Arizona.

The meeting was called to order by President Mike Lake at 7:00pm. In attendance were Rod Frazer, Allen Elvick, Mike Lake Bill Maynard and Aileen, Jan Lake, Sam Pernu, and new member Bob and Eileen Anderson formerly of the Portland Corsa club.

### Old Business

The Christmas party was a success. The silent auction raised some money for the club. Kettles Restaurant meeting place was lost due to them moving us to a different night. Meeting at the Golden Corral is not permanent. Next meeting place to be determined. The Pizza Hut on Campbell and Ft Lowell is a possibility.

Ken Farr's passing was brought to everyone's attention. Many comments were made about his commitment to Corvairs. He will be sorely missed by all TCA members.

The Trolley Museum tour: There are three different locations and the gathering place has yet to be determined. The time will likely be 10:30am. All those who agreed to attend will be notified. There is also a possibility we can meet for breakfast before the tour.

Mike Lake will be the intermediary to get club information to Van Pershing to communicate information for the newsletter and club website.

### New Business

Bob and Eileen Anderson from the Portland club were in attendance. Bob has much experience in differentials and drive trains. A tour of his shop may be in order.

Tubac car show will be held January 30.

Caliente Clowns Car Show will be held on February 20 in Florence.

Chevy Showdown will be at the Casino del Sol on April 30, 2016.

Thanks to Frank and Gloria Trejo a '64 Monza coupe was purchased as a Club project. Everyone is welcome to participate in the project by denoting some hard labor or needed parts. A list of needed items will be posted. The car is located at the Last Chance Garage where Corvair of all kinds are on the Vine.

The March activity will be a picnic at Madera Canyon. Mark March 16, 2016 on you calendars!

The slate of TCA officers for 2016 are:

President: Bill Maynard  
Vice President: Sam Pernu  
Board Member-at-Large: Mike Lake  
Recording Secretary: Frank Trejo  
Treasurer: Allen Elvick  
Corvairsation Editor/Webmaster: Van Pershing  
Membership Chairman: Ron Bloom

Upcoming Corvair events: Great Western Fan Belt Toss & Swap Meet will be in late October in Palm Springs. CORSA Nation Convention will be in Independence, Missouri June 27 through July 1, 2016.

Raffle winners were Ilene Anderson and Allen Elvick. Next meeting we hope to have the belt toss up and running to do a 50/50 payout.

Meeting adjourned at 7:55pm

*Submitted by Frank Trejo*

## President's Message

Well my run as Supreme Commander of the Tucson Corvair Association is just about over. LOL. It won't be long before the terror is over also! For someone who was reluctant to take the position of President, I am truly glad I did. I have learned a lot about myself from this experience as well as from each of you. Without you, this experience would not have been possible and/or pleasant. We have had a lot of laughs and good times, but also some lows with the recent passing of two club members. We need to honor their memories as Corvair guys and car guys in general by moving forward and keeping this great hobby of ours alive. They paved the path and pointed us in the right direction. Now it's up to us to continue down that path. I'm confident that our new President, Dr. Bill Maynard, will steer us correct.

At our last meeting we had two guests, Bob and Eileen Anderson, recent transplants from the Portland Oregon area. They were long time Corvair owners (since 1962) and members of the Portland Oregon Corvair Club. Also, Bob was the founder of CIDCO (Corvair Improvement Distributing Company) where he designed, manufactured and supplied transaxle parts such as reverse rotation ring and pinions, spider gear sets and HD transmission parts for the V8 crowd along with the racing crowd. They are now members of our club. We are proud to have them as club members.

Gary DeMass, former president of the Friends of Corvair Club in Ohio, has joined our club. Gary is a long time Corvair enthusiast with a Corvair lineage that goes back two generations. From what I recall from our conversation, Gary's grandfather and dad had a Chevrolet dealership. Gary comes to Tucson once a year and visited with us last time he was here. I am looking forward to seeing him again. We are also proud to have him as a club member.

As of this writing, we are contemplating a new location for the club meetings. This was discussed at this past meeting and the general consensus was the Pizza Hut on Campbell one block south of Fort Lowell. We plan on having our next meeting there to see what we think. This is not yet in stone as the Pizza Hut has yet to be contacted. They do however have a nice meeting room and a great place for us to park with maximum exposure. Please look for updates on this!

So, without further ado, I wish everyone the very best. Let's make this the best year ever for the Tucson Corvair Association.

God Bless

*Mike*

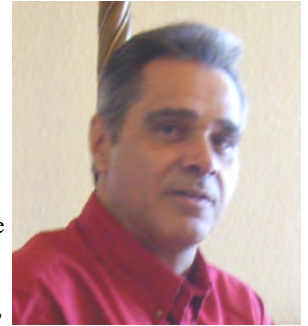

## Final Reminder

Your TCA dues for the 2016 year are due NOW.

Please send your dues in soon. \$15 per year for individuals and \$18 for families. Please make checks payable to the Tucson Corvair Association (TCA) and mail to the TCA Treasurer, Allen Elvick, 4210 S Preston, Tucson, AZ 85735 or bring your check to the next meeting.

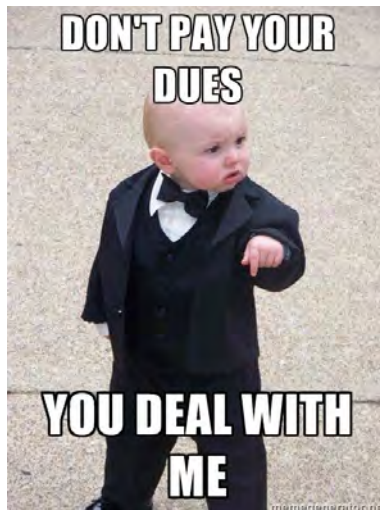

## Tech Tips

### Motor Oil

by Bob Nichols, South Coast CORSA

Lately I've read a number of articles about modern engine oils and how they relate to our Corvairs. This can be a very technical subject, but most of us just want a straight forward explanation that will keep our Corvairs running well.

**Viscosity:** Expressed on the oil container as a "SAE" number. The lower the number the thinner the oil (thinner oil is needed in freezing conditions). The higher the number the thicker the oil for high temperature operation.

Single weight = the oil "thickness" is rated for engine operating temperatures ONLY. SAE 30 weight is a good average for California BUT is too thin for days over 86 degrees and it will be too thick at 32 degrees or less. Single weight oils are NO LONGER recommended for normal use in automobiles, including Corvairs.

Multi weight or Multi viscosity: Additives are put into the oil so it can be thin for cold starting, but will have the lubricating protection of the higher number when the engine is hot. SAE 20W40 is good for most Corvairs (20W50 for days over 90). (Note: 10W is for starting an engine at -4 degrees and 10W40 is not recommended for use in California).

**Oil change intervals:** The intervals between oil changes is now generally advertised at 7,500 miles **HOWEVER** the "severe duty" recommendation is 3,000 miles or once a year (whichever comes first). Severe duty is generally described as "stop and go" (lots of city driving or rush hour on the freeway), short trips (less than 10 miles) and high temperature operation (pulling loads, high speed driving, driving when the outside temperature is over 86). Simply put – most of us are in the "severe duty" category. Change the oil, save the engine.

Thanks to  
Mike Dawson,  
Central Oklahoma  
Corvair Association

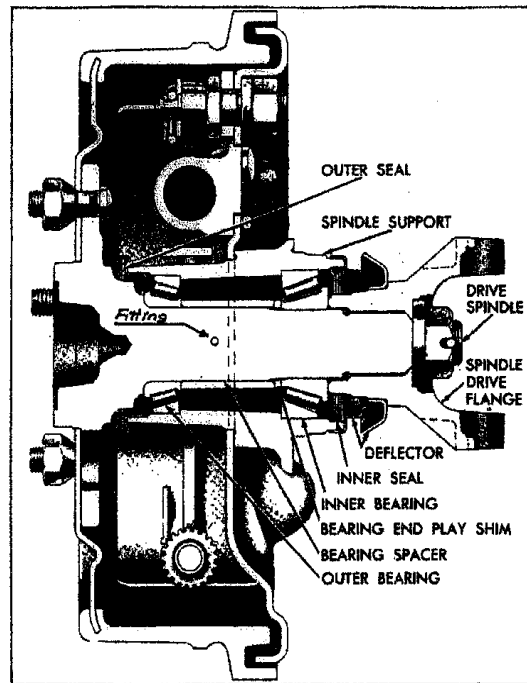

Fig. 66—Wheel Spindle and Support Cross Section

### Packing Rear Wheel Bearings: 1965-1969

1. Remove brake shoes and outer U-joint so you can feel the bearings as you rotate the hub by hand.
2. Drill and tap a hole for a grease fitting, 1/2 inch out from the backing plate. Drill a 1/8 inch pilot hole, and then use a #3 bit. Tap for 1/4 - 28, which is the standard grease fitting thread. Other sizes could be used. Coat the tap with grease to catch chips.
3. Use a high quality wheel bearing grease in a gun to pack the bearings as you check the turning of the bearings by hand after about 20 pumps (if this is the first packing). The fitting is installed between the two bearings and the new grease forces the old grease to the outside of the bearing against the seal. As you reach the proper amount of grease, the rotating of the hub will suddenly be quieter and show resistance to turning. At this point, remove the fitting and let any trapped air out. Reinstall the fitting and use two or three more pumps to complete packing.
4. Do not over pack, as you can pop the outer seal out of the hub (replace it with two prybars). Also, too much grease can find its way on to your brake shoes. If you suspect this, drive at highway speed for a few minutes, remove the fitting to check for excess pressure, and clean brakes if necessary with brake cleaner.
5. You can repack the bearings again after 20,000 miles by following #1 above but only using a few pumps of grease.



John and Amy  
Young's '66 Turbo  
Corsa convertible.



# Great Project Car!

Recently a purchase was made of a very solid '64 Monza 4-speed coupe for \$150 as a club project. It is the intension to remove the FC motor that is presently in the car and install a 110hp engine. Parts from other cars and parts that are stashed here and there will be used to bring the car back from the dead. Club members can help with the labor and donations of parts for the project are greatly welcomed. Once complete the car will be sold with all proceeds going into the club's treasury. The car needs tires, brakes and other odds and ends. This looks like a fun project!





**Monthly Newsletter - February 2016 - Vol. 40, No. 8  
Corvair Society of America Chapter 857**



Regular Monthly Meetings are held on the Fourth Wednesday of every month with a bull session starting at 6:30pm with the meeting starting at 7:00pm.

The November meeting is traditionally held on the third Wednesday. The December meeting is our annual Christmas party with the time and place to be announced.

**NEW MEETING PLACE for February:**

**Pizza Hut, 2943 N Campbell (2 blocks south of Ft Lowell)  
Tucson, Arizona.**

Board of Director meetings are held at 5:30pm before the regular monthly meeting at the same location in the months of January, April, July, and October. All members are welcome to attend.

This newsletter can also be accessed at [www.corvairs.org](http://www.corvairs.org)



Tucson Corvair Association  
4842 W Paseo de las Colinas  
Tucson, AZ 85745

February 2016

Volume 40, Number 8

